

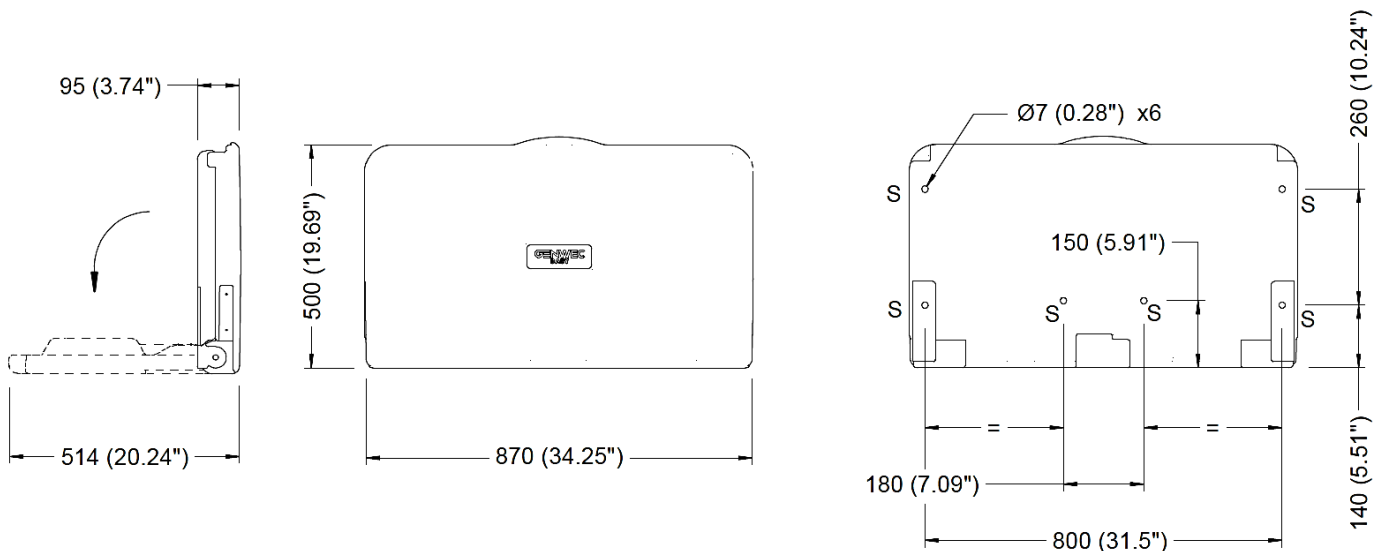

GW07 05 01 00

"Genwec Baby" horizontal baby changing station



PRODUCT DESCRIPTION

COMPONENTS AND MATERIALS

- Baby change station manufactured in Polyethylene with antimicrobial additive embedded into the surface.
- Soft open/close mechanism with reinforced heavy-duty Steel hinges and pneumatic cylinder.
- Mounting hardware included with the unit

OPERATION

Open "Genwec baby" baby change station completely. Place the baby on the centre of the bed and secure by using strap provided. Change the baby diaper and close baby change station to its original position.

MOUNTING

Always fix the baby changing station to the wall using the screws supplied with the unit. Screws should be fixed through the unit keyhole slots. Always follow step by step the "Installation and mounting manual" supplied with the unit.

ARCHITECTURAL SPECIFICATION

"Genwec Baby" wall mounted baby changing unit. Manufactured with injection-moulded Polyethylene. Unit is equipped with a pneumatic cylinder for a soft opening and close. Bed is secured with heavy duty steel hinges and includes antimicrobial additive in its surface. All mounting hardware shall be included. The bed has a smooth concave changing area with security nylon strap and two hooks for bags. Unit shall have a built-in liner dispenser, universal instruction graphics and safety messages in 3 languages. Unit shall be backed by manufacturer's 2 years limited warranty on materials. Unit is designed to conform to standards EN-12221-1:2008+A1:2013, EN-12221-2:2008+A1:2013, ATSM 2285-04, Rohs 2015/863.

SPARE PARTS

- GW07 05 90 00 Unit mounting hardware
- GW07 05 90 01 Security strap
- GW07 05 90 02 Heavy duty steel hinges (2 units)